

RABBETSPACE

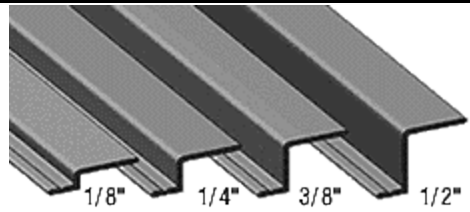

- S2421 Rabbetspace 1/8"
- S2422 Rabbetspace 1/4"
- S2423 Rabbetspace 3/8"
- S2424 Rabbetspace 1/2"



- Neutral pH. Safe for important art
- Satin black acrylic with discreet design gives finished appearance.
- Variety of sizes. Makes framing challenges of any size easier.
- Matching black-plated screws included.
- No dust cover paper required.
- Assortment kit includes tools for easy installation.

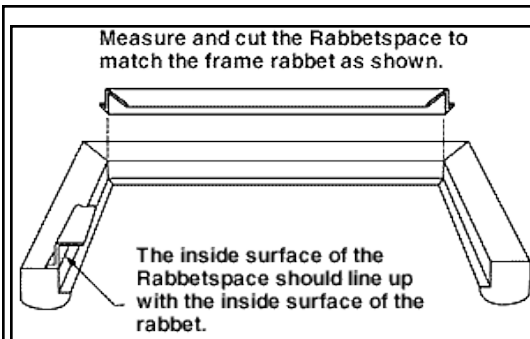

The Rabbetspace will line up flush with the inside rabbet of your picture frame. (See above picture for a side view)

Measure and cut the Rabbetspace to match the frame rabbet as shown in the diagram to the left.

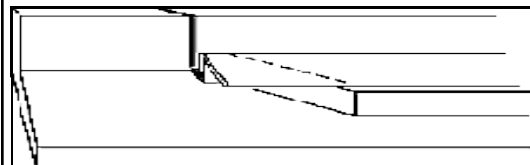

Wooden strips support Rabbetspace in chopper or saw when cutting. The wooden strips are available in four sizes to match the four different Rabbetspace depths.

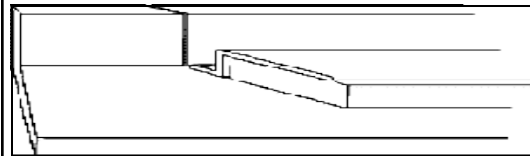

Position the wood strip back just a little so you don't cut it each time. Sticking the wood strip down to the base of your saw with ATG tape will help a lot.

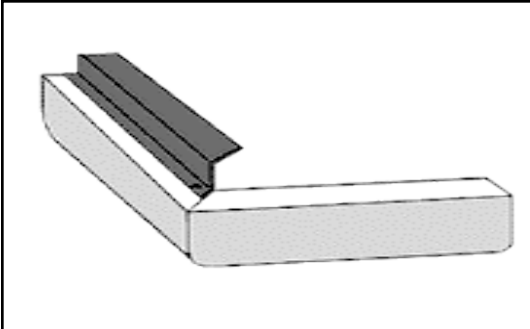

In the empty frame, drill one 1/16" pilot hole 1/4" deep and 3/32" clearance hole through just the plastic near the corner and attach the Rabbetspace temporarily with a screw at the corner. (A clearance hole is necessary to prevent buckling from expansion.) A special drill is available from Frame Tek that drills both holes at the same time. Now drill all the rest of the holes for that side. Make sure that the inside of the Rabbetspace is flush with the inside of the frame when you drill each hole.

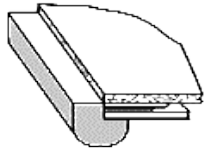
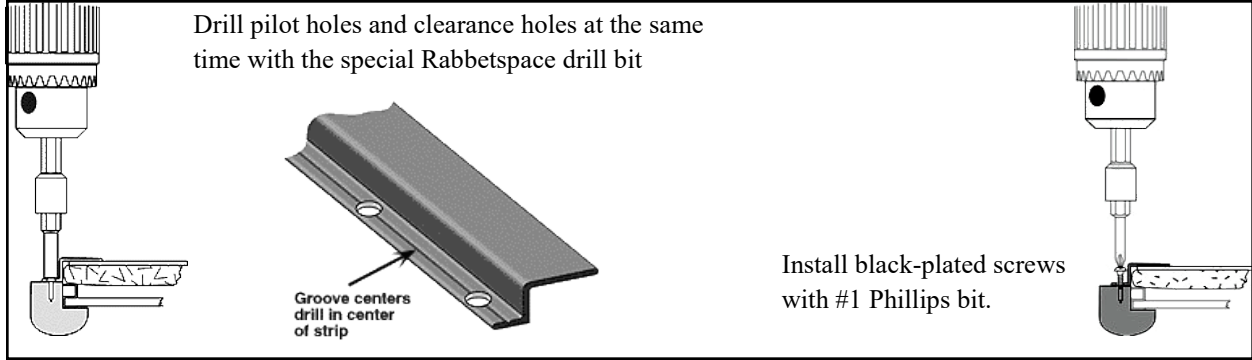

PROBLEM:
Too much art for the frame....

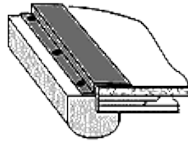

SOLUTION: Secure the art and finish off the back of the frame quickly, easily and neatly, using Rabbetspace

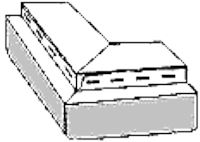

PROBLEM:
An oil painting sticks out the back of a shallow frame and looks unsightly.

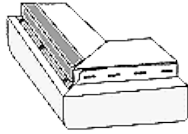

SOLUTION: Use Rabbetspace to secure a stretched canvas in a shallow frame and cover the edges neatly in just a few minutes.

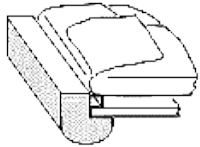

PROBLEM:
Needle art and spacer won't both fit in the frame.

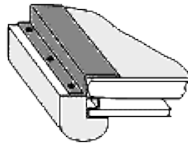

SOLUTION: Cover the lumpy back of needlework with black rag board and secure it in the frame with Rabbetspace-a professional looking solution in just minutes.